

4.5-6.5GHz Medium Power Amplifier

GaAs Monolithic Microwave IC

Description

The CHA4107-99F is a monolithic two stage power amplifier designed for C-Band applications.

The MPA provides typically 26dBm output power associated to 35% power added efficiency at 3dBcomp.

The circuit is manufactured with a pHEMT process, 0.25 μ m gate length, via holes through the substrate, air bridges and electron beam gate lithography. It is available in chip form.

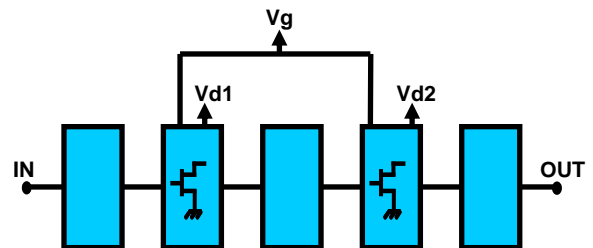

Main Features

- Frequency band: 4.5-6.5GHz
- 26dBm @ 3dBcomp
- 24.5 dB Linear Gain
- High PAE: 35% for +5dBm input power
- DC bias: Vd=8V@Id=115mA
- Chip size 2.37x1.5x0.07mm

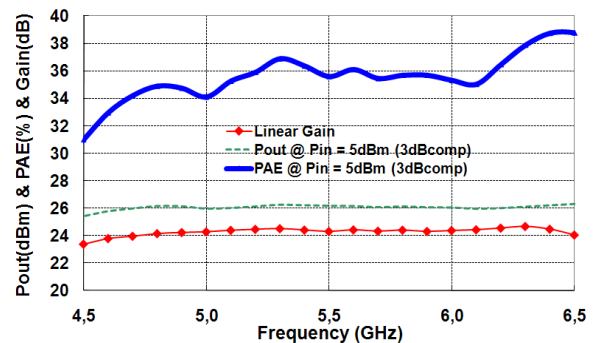

Main Characteristics

Vd = 8V, Id (Quiescent) = 115 mA, Drain Pulse width = 45 μ s, Duty cycle = 12%

Symbol	Parameter	Min	Typ	Max	Unit
Freq	Frequency range	4.5		6.5	GHz
Gain	Linear Gain		24.5		dB
NF	Noise Figure		5		dB
Pout	Output Power @ 3dB comp.		26		dBm

Electrical Characteristics

Vd = 8V, Id (Quiescent) = 115 mA, Drain Pulse width = 45µs, Duty cycle = 12%

Symbol	Parameter	Min	Typ	Max	Unit
Freq	Frequency range	4.5		6.5	GHz
Gain	Linear Gain		24.5		dB
NF	Noise Figure		5		dB
RLin	Input Return Loss		13		dB
RLout	Output Return Loss		8		dB
P_1dBc	Output power @ 1dBcomp		25		dBm
P_3dBc	Output power @ 3dBcomp		26		dBm
PAE_3dBc	Power Added Efficiency @ 3dBc		35		%
Id_3dBc	Supply drain current @ 3dBc		130		mA
Vd1, Vd2	Drain supply voltage		8		V
Id	Supply quiescent current (1)		115		mA
Vg	Gate supply voltage		-0.8		V

These values are representative of on-Jig measurements.

(1) Parameter can be adjusted by tuning of Vg.

Absolute Maximum Ratings ⁽¹⁾

Tamb.= +25°C

Symbol	Parameter	Values	Unit
Cmp	Compression level ⁽²⁾	6	dB
Vd	Supply voltage	9.5	V
Id	Supply quiescent current	250	mA
Id_sat	Supply current in saturation	350	mA
Vg	Supply voltage	[-3.0; -0.4]	V
Tj	Maximum junction temperature	175	°C
Tstg	Storage temperature range	-55 to +150	°C
Top	Operating temperature range	-40 to +85	°C

(1) Operation of this device above anyone of these parameters may cause permanent damage.

(2) For higher compression the level limit can be increased by decreasing the voltage Vd using the rate 0.5V/dBcomp.

Typical on-wafer Sij parameters

Tamb.= +25°C, Vd = +8V, Id = 115mA

Freq (GHz)	S11 (dB)	PhS11 (°)	S12 (dB)	PhS12 (°)	S21 (dB)	PhS21 (°)	S22 (dB)	PhS22 (°)
2.00	-3.71	-43.44	-63.21	-139.00	5.79	166.00	-8.39	31.33
2.40	-3.85	-49.94	-63.68	-72.72	10.38	95.99	-7.92	-25.37
2.80	-4.02	-57.93	-63.92	164.50	12.30	48.66	-10.56	-34.55
3.20	-4.46	-69.48	-48.25	120.80	14.21	11.12	-10.62	-29.96
3.60	-5.24	-83.39	-60.90	170.80	16.68	-23.41	-9.14	-30.55
4.00	-7.12	-97.66	-70.26	-57.20	19.36	-59.84	-8.22	-43.06
4.40	-10.98	-106.30	-52.87	-7.31	21.91	-103.70	-8.02	-56.73
4.80	-13.83	-90.00	-48.62	22.44	23.30	-150.90	-8.67	-68.98
5.20	-12.93	-82.05	-49.80	-23.29	23.52	163.50	-9.11	-79.47
5.60	-13.52	-85.54	-57.81	-65.50	23.52	121.40	-8.78	-92.08
6.00	-14.21	-73.76	-49.52	-124.40	23.65	77.11	-8.20	-113.30
6.40	-11.03	-69.98	-51.47	-177.10	23.16	28.73	-8.47	-141.30
6.80	-8.33	-89.16	-52.36	159.00	21.03	-21.97	-10.46	-173.00
7.20	-7.75	-112.90	-63.26	142.80	17.81	-66.68	-12.94	164.30
7.60	-7.77	-130.30	-69.48	2.62	14.02	-103.70	-14.57	143.70
8.00	-7.68	-148.30	-53.55	121.40	10.28	-136.90	-15.74	130.80
8.40	-7.21	-166.40	-59.68	8.18	6.56	-166.10	-14.85	120.40
8.80	-6.84	175.30	-51.19	138.20	2.62	166.90	-14.71	114.80
9.20	-6.19	159.50	-50.78	-51.15	-1.14	143.70	-13.35	106.30
9.60	-5.86	143.80	-55.03	-47.20	-4.96	122.70	-12.13	98.57
10.00	-5.46	128.60	-52.40	-146.90	-8.67	103.10	-10.43	91.47
10.40	-4.84	116.20	-62.55	-176.60	-12.02	85.93	-9.05	85.73
10.80	-4.77	104.70	-48.22	-131.80	-15.66	70.81	-8.17	78.93
11.20	-3.96	93.63	-48.09	-93.38	-18.84	54.85	-7.21	71.07
11.60	-3.67	87.22	-48.28	55.47	-21.78	41.57	-6.18	62.82
12.00	-3.37	75.38	-59.40	173.70	-25.54	29.73	-5.44	60.08
12.40	-3.35	70.02	-52.11	-103.20	-28.37	20.69	-4.30	52.83
12.80	-3.11	57.48	-43.51	175.10	-31.95	0.60	-3.94	47.00
13.20	-1.64	56.46	-44.50	55.48	-32.32	-8.66	-3.00	35.69
13.60	-1.74	48.11	-45.37	141.30	-37.42	-26.74	-3.14	26.64
14.00	-1.83	43.10	-53.12	119.10	-39.44	-40.94	-2.82	24.77

Typical on-wafer Sij parameters

Tamb.= +25°C, Vd = +8V, Id = 115mA

Freq (GHz)	S11 (dB)	PhS11 (°)	S12 (dB)	PhS12 (°)	S21 (dB)	PhS21 (°)	S22 (dB)	PhS22 (°)
14.40	-1.57	41.82	-56.19	59.72	-46.09	-48.43	-1.59	19.73
14.80	-1.17	32.98	-40.02	-169.00	-51.16	-127.00	-1.49	15.50
15.20	-1.84	24.26	-40.17	-71.68	-47.88	-59.04	-2.12	11.99
15.60	-0.89	19.12	-51.96	-16.02	-49.10	-76.69	-1.77	4.34
16.00	-1.09	26.33	-54.17	-178.80	-42.14	-83.60	-0.50	2.88
16.40	-1.09	9.86	-51.44	174.50	-50.02	157.60	-1.75	-3.97
16.80	-0.36	8.65	-44.47	-19.29	-45.84	-16.49	-0.61	-10.70
17.20	-0.85	6.22	-44.09	60.04	-53.59	50.86	-0.66	-9.31
17.60	-0.31	-2.44	-46.94	8.43	-48.01	97.35	-1.29	-18.54
18.00	-0.86	-0.40	-47.33	-162.90	-48.23	69.86	-0.66	-20.51

Typical on Jig Measurements

Tamb.= +25°C,

Vd = 8V, Id (Quiescent) = 115mA, Drain Pulse width = 45µs, Duty cycle = 12%

Linear Gain versus frequency

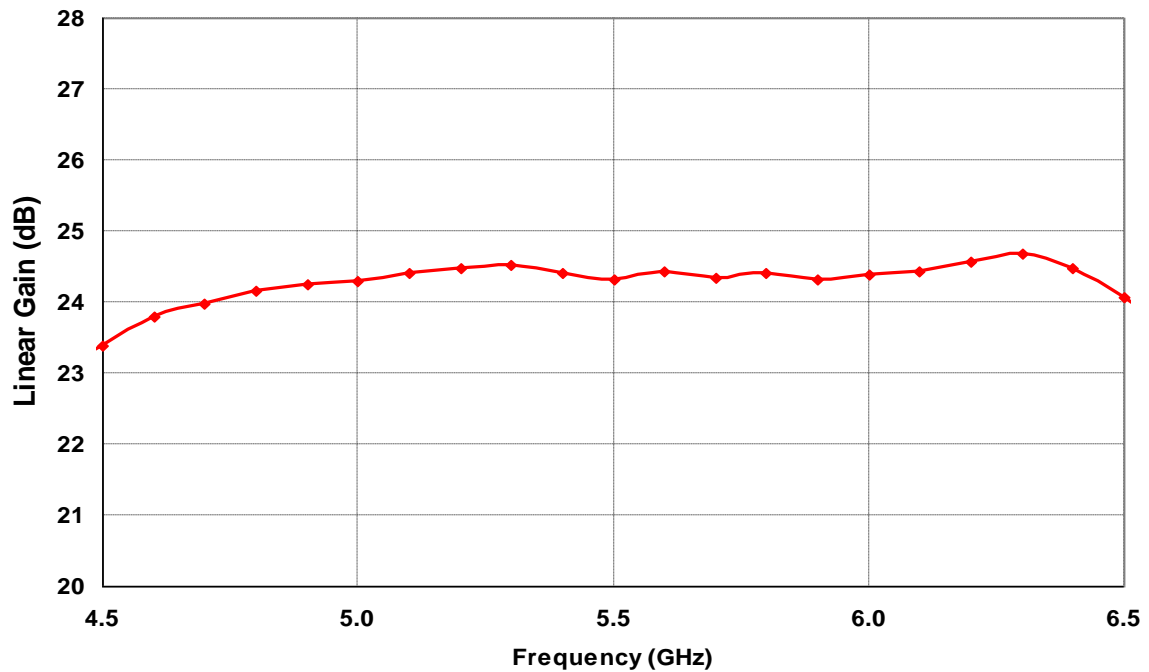

Output Power @ 3dBcomp versus frequency

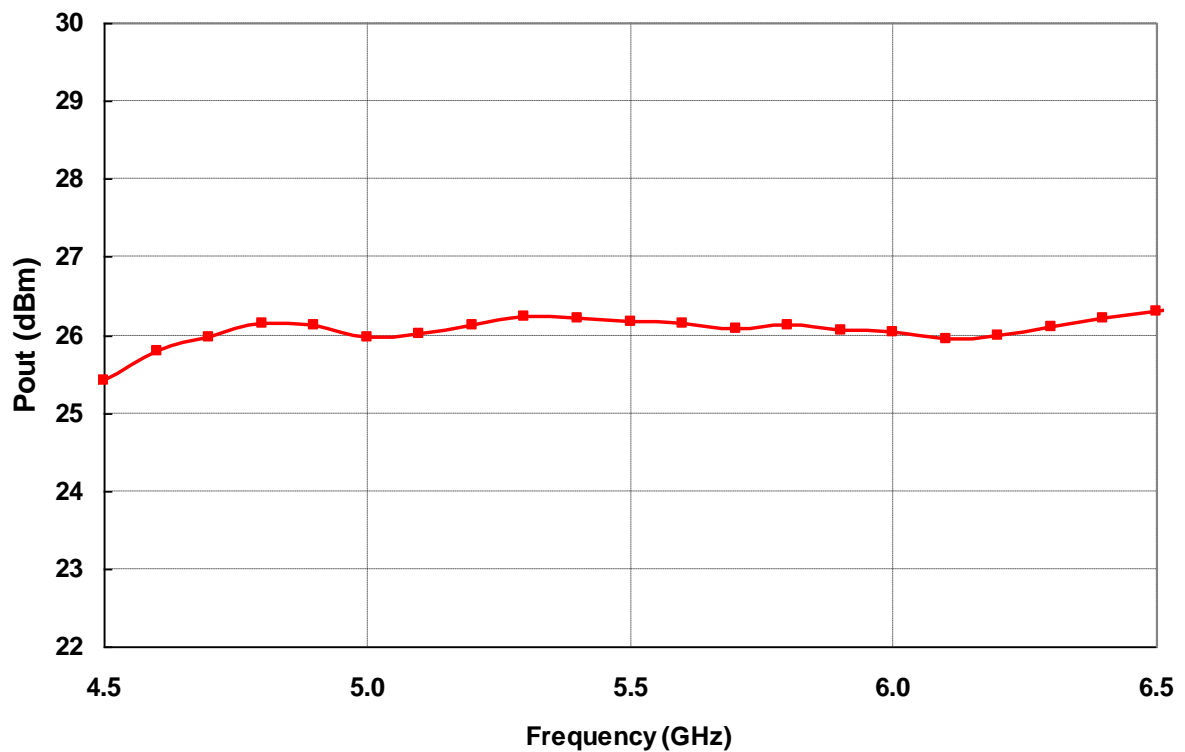

Typical on Jig Measurements

Tamb.= +25°C,

Vd = 8V, Id (Quiescent) = 115mA, Drain Pulse width = 45µs, Duty cycle = 12%

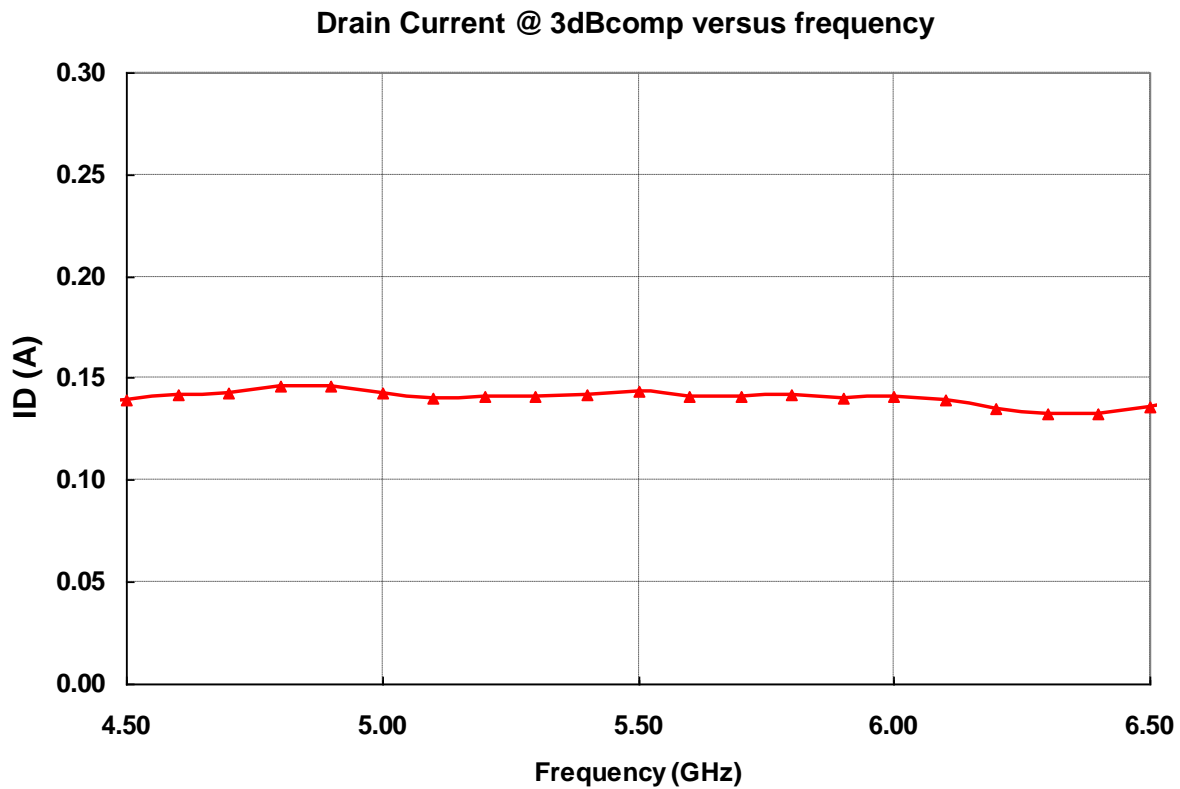
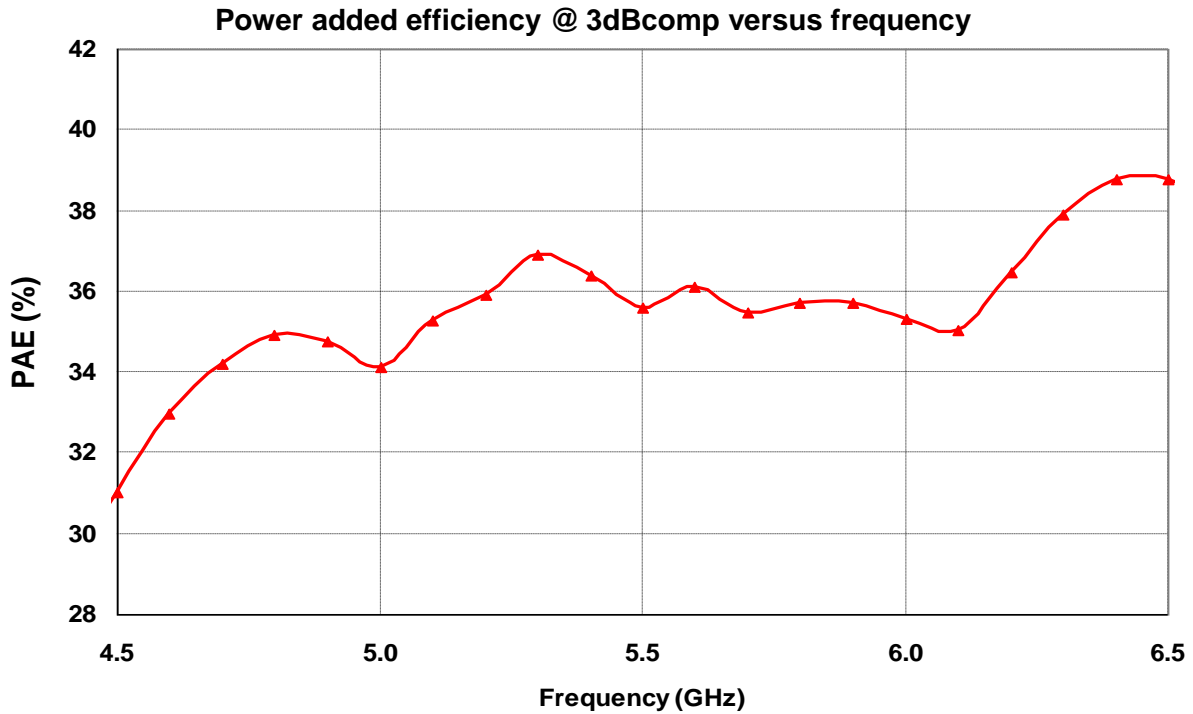

Mechanical data

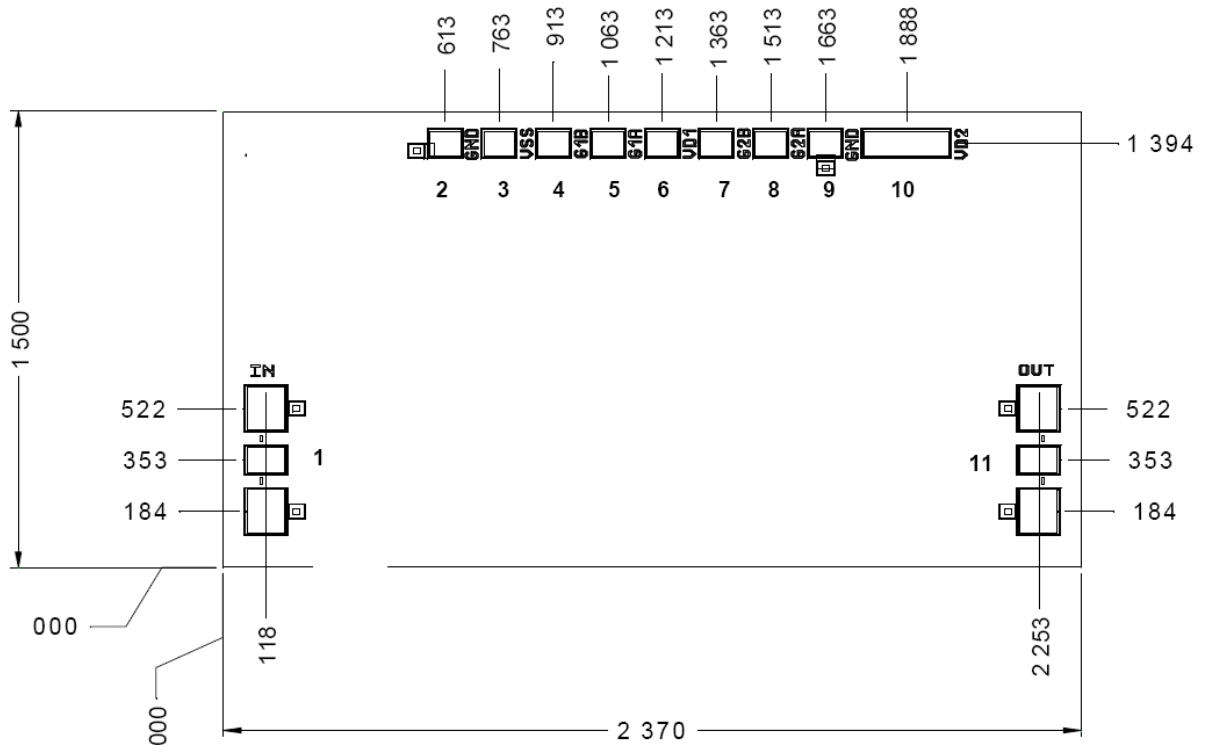

UNITS : μm
Tol : $\pm 35\mu\text{m}$

All dimensions are in micrometers
 Chip size = $1500 \times 2370 \pm 35\mu\text{m}$
 Chip thickness = $70\mu\text{m} \pm 10\mu\text{m}$
 RF pads (1, 12) = $100 \times 122\mu\text{m}^2$
 DC pads (3, 6, 8, 11) = $100 \times 100\mu\text{m}^2$
 Chip width and length are given with a tolerance of $\pm 35\mu\text{m}$

Pin number	Pin name	Description
1	IN	RF Input
3, 4, 7, 8	Vss, G1B, G2B, G2A	NC
5	G1A	Vg
2, 9	GND	NC
6, 10	VD1, VD2	Vd
11	OUT	RF Output

Recommended assembly plan

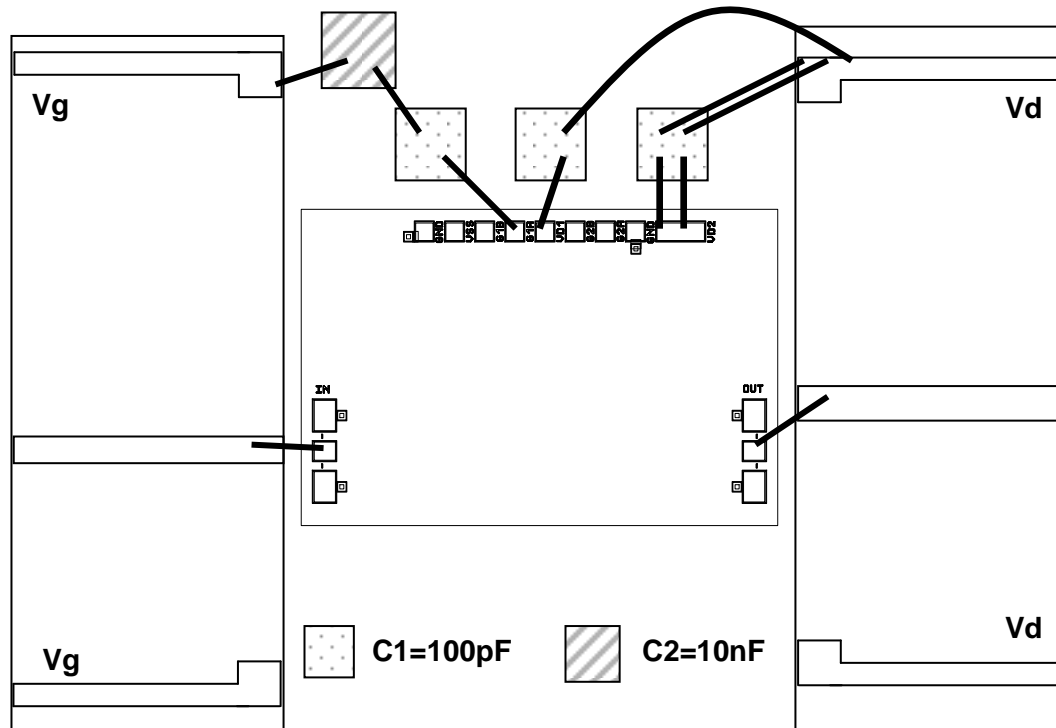

Pads G1A (pin 5) & G2A (pin 8) are connected inside the chip, The CHA4107 could be used without G2A bias. There is a resistor bridge inside the chip. This one generates the correct value of G1A Bias. Equivalent RF Wire Bonding: 0.2nH (typical length of 200 μ m for a 25 μ m diameter wire).

Bonding recommendations

Port	Connection	External capacitor
IN	Inductance (L_{bonding}) = 0.2nH 1 gold wire with diameter of 25 μ m	
OUT	Inductance (L_{bonding}) = 0.2nH 1 gold wire with diameter of 25 μ m	
Vg	Inductance \leq 1nH	C1 ~ 100pF, C2 ~ 10nF
Vd	Inductance \leq 1nH	C1 ~ 100pF

DC Schematic

Medium Power Amplifier: 8V, 115mA

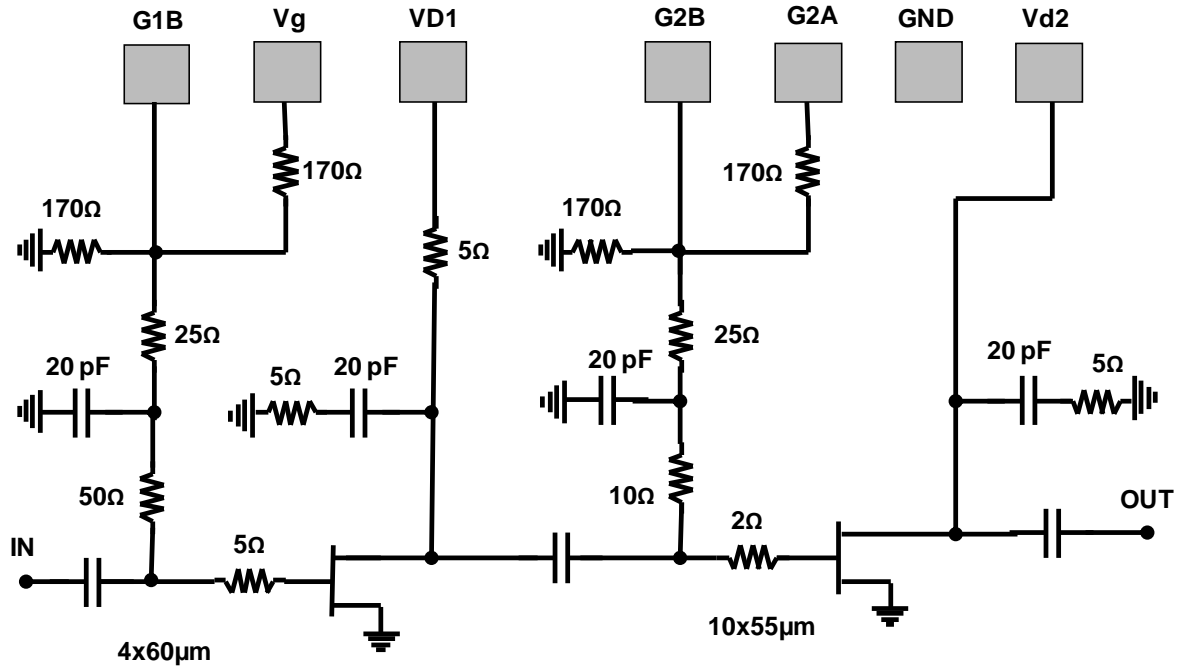

Recommended ESD management

Refer to the application note AN0020 available at <http://www.ums-gaas.com> for ESD sensitivity and handling recommendations for the UMS products.

Recommended environmental management

UMS products are compliant with the regulation in particular with the directives RoHS N°2011/65 and REACH N°1907/2006. More environmental data are available in the application note AN0019 also available at <http://www.ums-gaas.com>.

Ordering Information

Chip form:

CHA4107-99F/00

Information furnished is believed to be accurate and reliable. However **United Monolithic Semiconductors S.A.S.** assumes no responsibility for the consequences of use of such information nor for any infringement of patents or other rights of third parties which may result from its use. No license is granted by implication or otherwise under any patent or patent rights of **United Monolithic Semiconductors S.A.S.** Specifications mentioned in this publication are subject to change without notice. This publication supersedes and replaces all information previously supplied. **United Monolithic Semiconductors S.A.S.** products are not authorised for use as critical components in life support devices or systems without express written approval from **United Monolithic Semiconductors S.A.S.**